

Universidad ORT Uruguay
Facultad de Comunicación y Diseño

Carpeta anual 4
Entregado como requisito para la obtención del título de
Licenciado en Diseño Industrial

Martín Pérez Leiza
154037
2015

CAP 4

Martín Pérez Leiza

Lic. Diseño Industrial

... será la última ?

Fluir es el mejor sinónimo que me define a la hora de diseñar. Mis aliados; la mejora continua, paciencia, contemplación de los detalles, decantan en un experiencia que absorbe por completo mi persona. Sumergido en esta experiencia, es que me lanzo en la ambiciosa idea de crear un obra que llene las mas altas expectativas.

Circuler est le meilleur synonyme que me définit lors de la conception. Mes alliés; l'amélioration continue, la patience, la contemplation des détails, décantée dans une expérience qui m'absorbé complètement. Immergé dans cette expérience est que je lançai dans l'idée ambitieuse de créer une œuvre qui répond aux attentes les plus élevées.

01- TIUB
Mobiliario



02- P&S
Utencillos

03- Furn-Flex
Mobiliario



04- Cuadros y Gráfica
Decoraciones

05- Percheros
Percheros



06- Colonial
Carro de garrapiñada

07- Queen speak
Parlantes

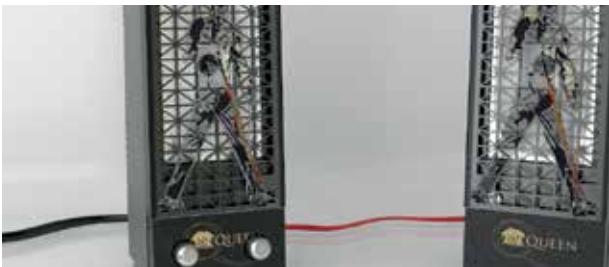

08- Kendama
Juego



| 01 - TIUB

01- TIUB

Mueble para colocar
ropa y accesorios.
Trabajo realizado para
el museo MAPI.

*Meuble rangement de
vêtements et
accessoires
Travail réalisé pour le
Musée Anthropologique*





El mueble cuenta con un espacio para guardar el stock y un espejo.

Se puede mover fácilmente debido a las ruedas que se encuentran en la base.

Le meuble a un espace de rangement de stock et un miroir.

Facilement déplaçable, grâce aux roulettes.

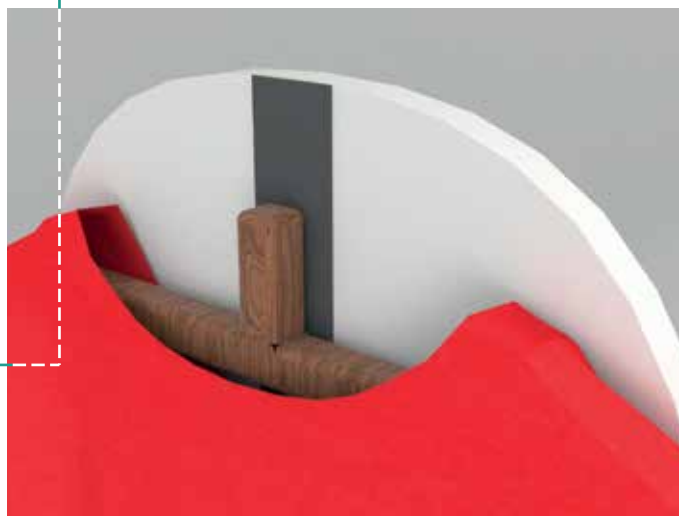
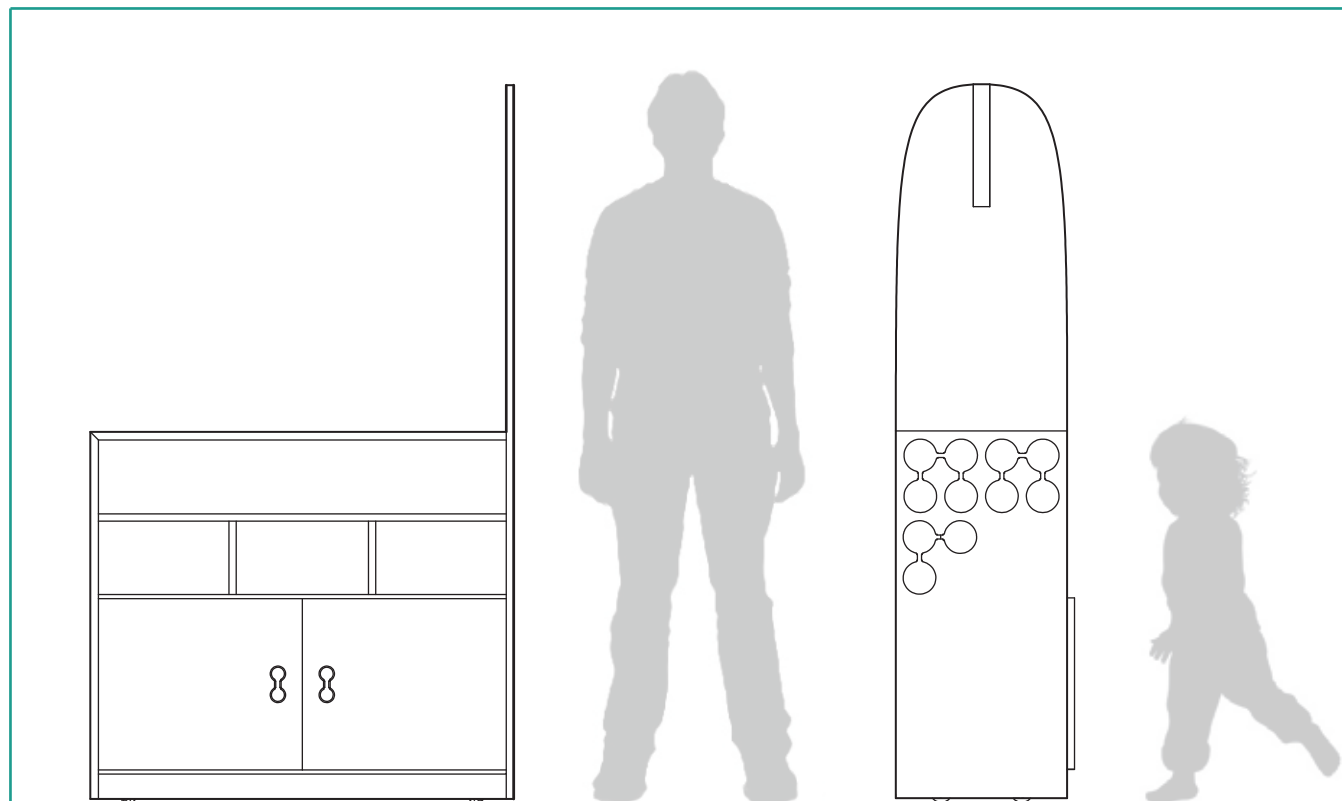





02 - P&S

02- P&S

El salero tiene aristas curvas respetando su concepto de suave mientras que el pimentero termina en punta haciendo alusión al concepto árido.

Realizados en cerámica, color blanco.

La salière de ligne douce et épurée a des arêtes courbes et arrondies, tandis que le poivrier présente une ligne plus aride et finit en pointe.

Réalisés en céramique blanche.







| 03 - Furn-Flex

03- Furn-Flex

Mesa y taburete para ser utilizados en los espacios de estudios universitarios. Ambos son armables y plegables.

Table et tabouret conçus pour des espaces de travail des étudiants universitaires. Les deux peuvent être montés et pliés.





Go

Fr

Handwritten decorative script on the orange wall.



Las mesas cuentan con enchufes en dos de sus lados.

Les tables ont des prises électriques des deux côtés.

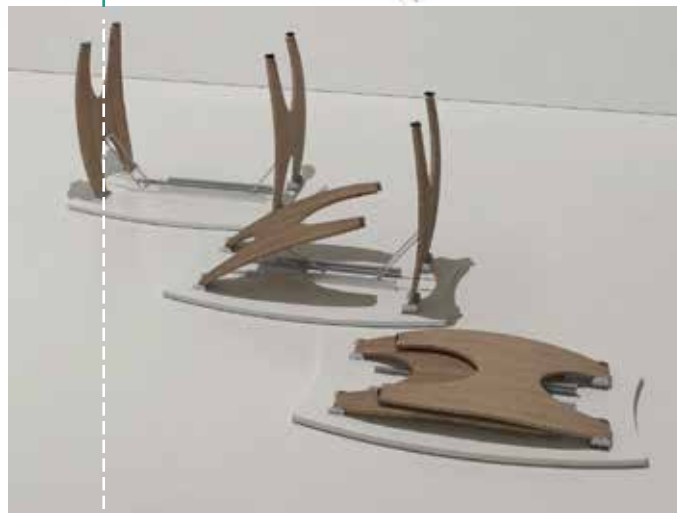
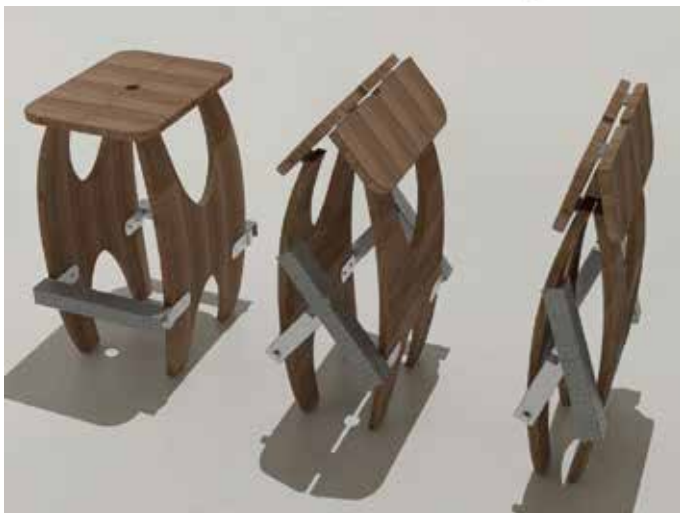
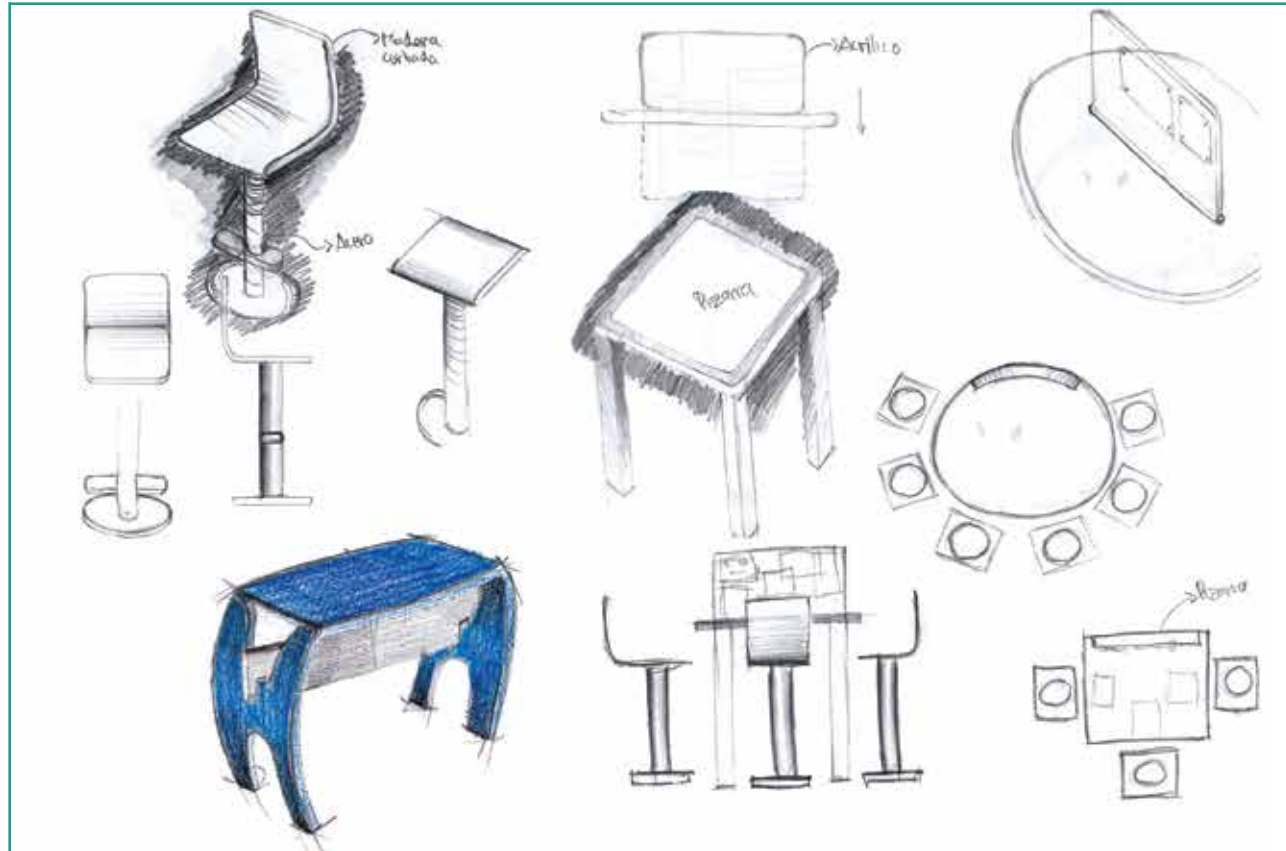
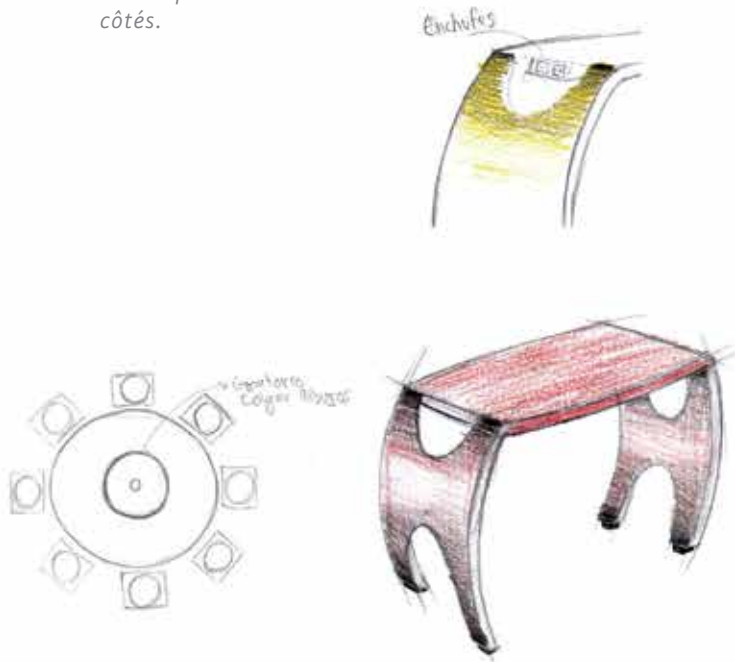





|04- Cuadros & Gráfica



Aplicación grafica sobre guitarra en forma de vinilo.



Trabajo de pintura sobre guitarra

04- Cuadros & Gráfica

Cuadros realizados en MDF con fondo melamínico

Tableaux en MDF à surface mélaminée.

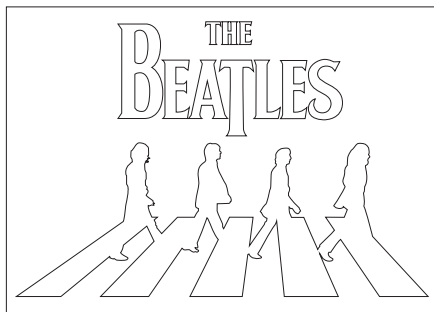

1- Dibujo vectorial del motivo a realizar



2- Corte laser sobre MDF



3- Armado de la estructura del cuadro



4- Pintado y colocación de melamínico

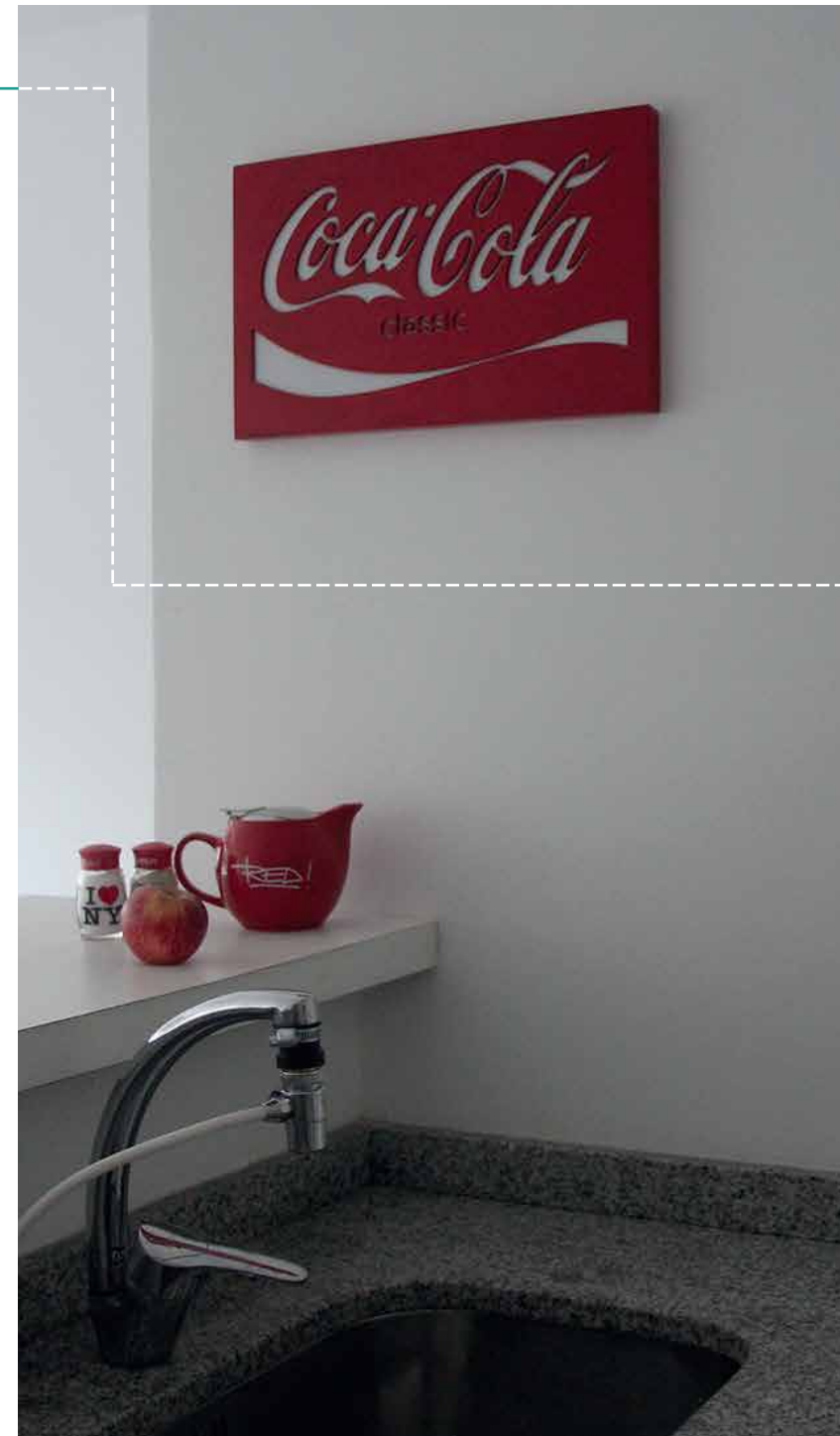



05- Percheros

05- Percheros

Percheros
personalizados
realizados en madera
con una luz interna.

*Portemanteaux
personnalisés, en bois,
avec lumière à
l'intérieur.*







|06- Colonial



Garrapiñada
Gloria
Pebip
Moreta
\$20

06- Colonial

Carro de garrapiñada.
Estilo colonial.

*Chariot d'élaboration et
vente de cacahouètes
caramélisés style
colonial américain.*

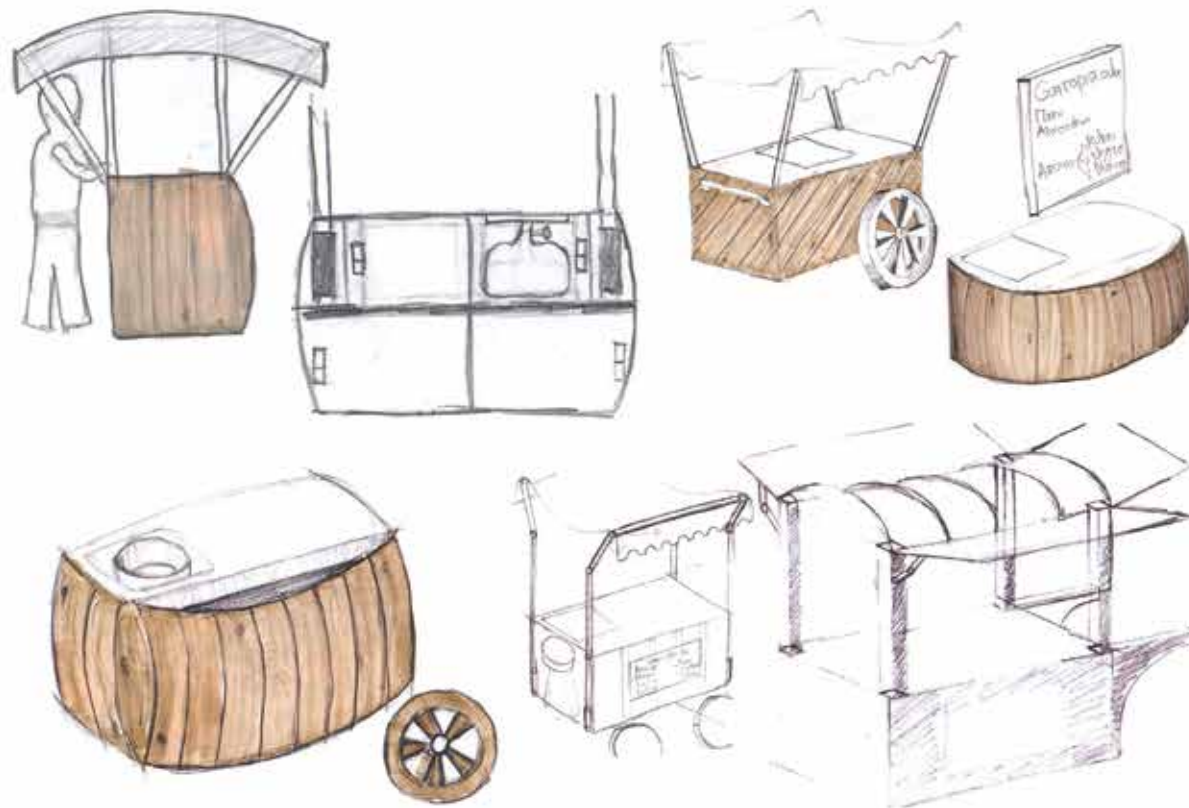

Cuenta con un espacio para colocar la garrafa con la olla y otro donde disponer la garrapiñada ya pronta.

Il dispose d'un espace pour la carafe avec le pot et un autre où disposer la garrapiñada déjà prêt.





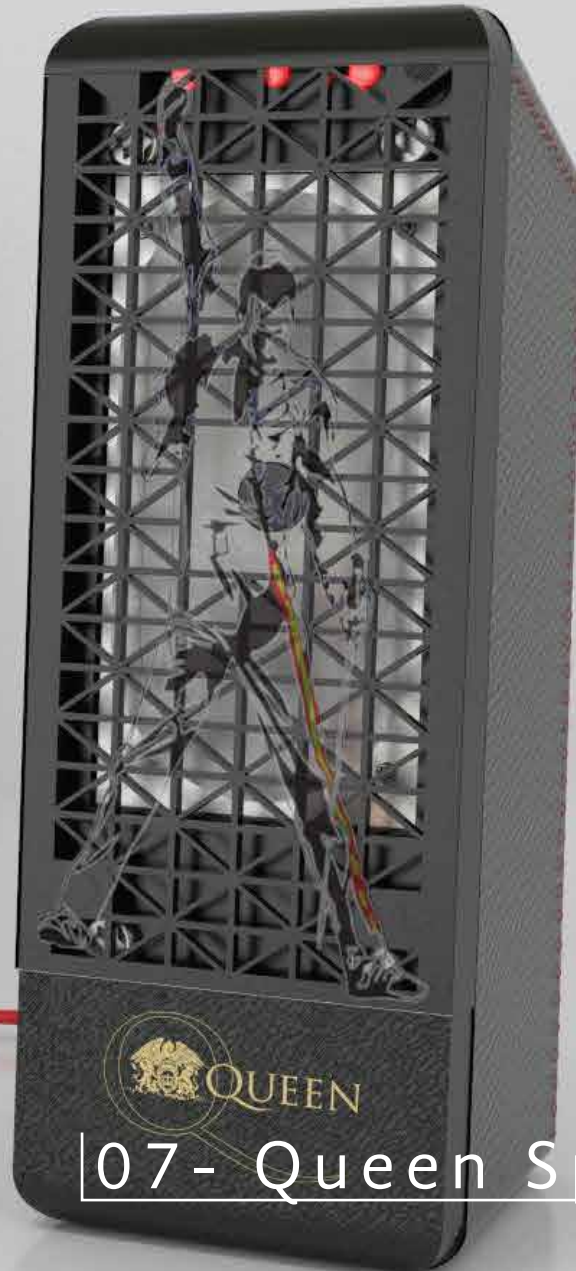

| 07 - Queen Speakers

07- Queen Speakers

Parlantes temáticos.
Banda Queen.
Terminaciones en
cuero, con luces LED y
botones metalizados.

*Hauts parleurs
thématiques
Groupe Quenn
Finition en cuir, et
boutons métallisés.*

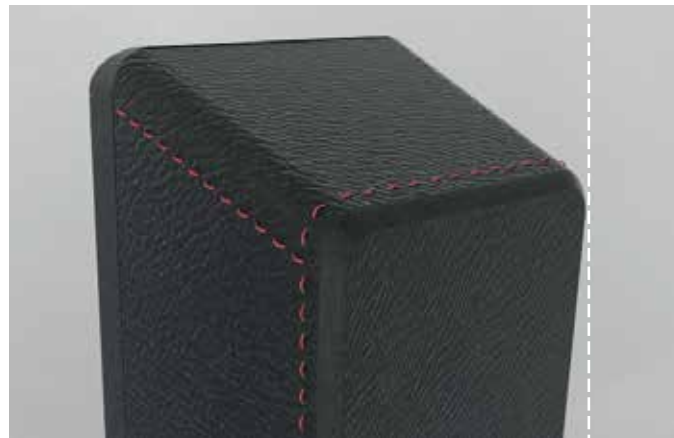
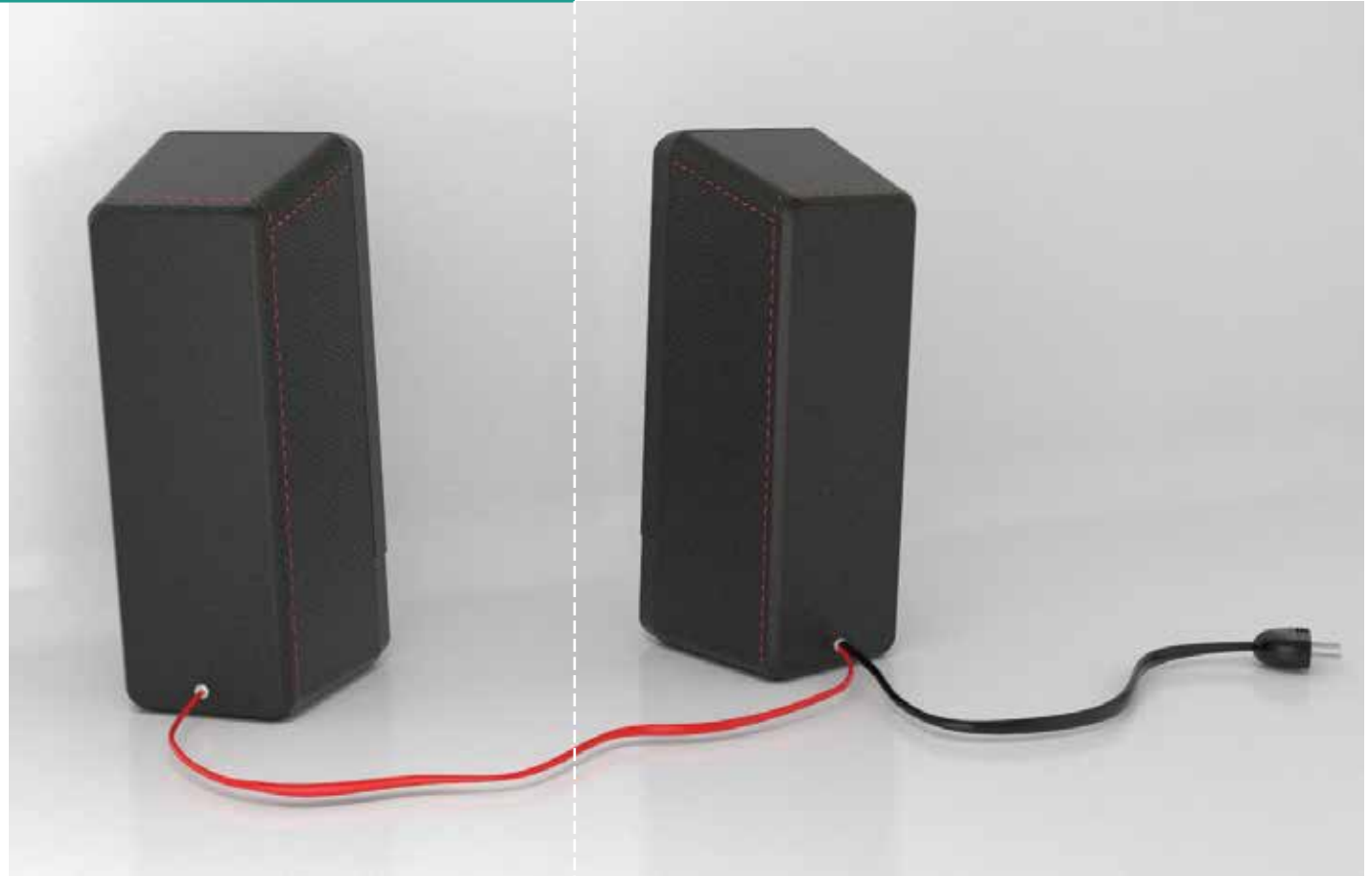





| 08 - Kendama

08- Kendama

Juego de lanzamiento de pelotas. Inspirado en las viejas batallas de barcos con cañones.

Kendama tiene lanzadores de pelotas que deben ser embocadas en los ductos del equipo contrario.

Jeu lance balles, inspiré des vieilles batailles navales de bateaux à canons.

Kendama a des lanceurs de balles qui doivent les faire passer par des conduits de l'équipe adverse.

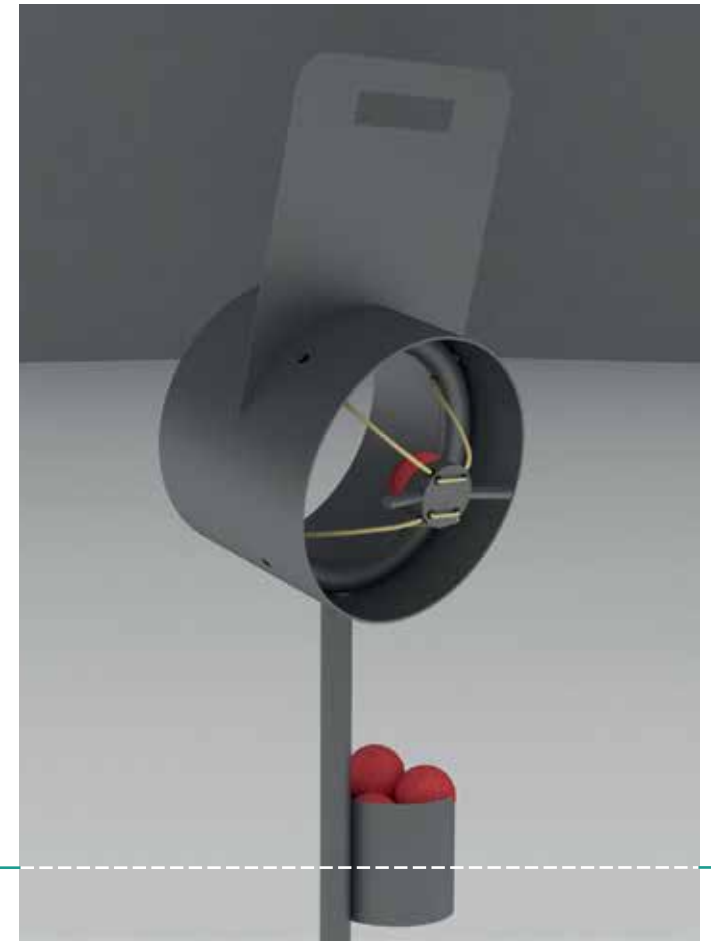
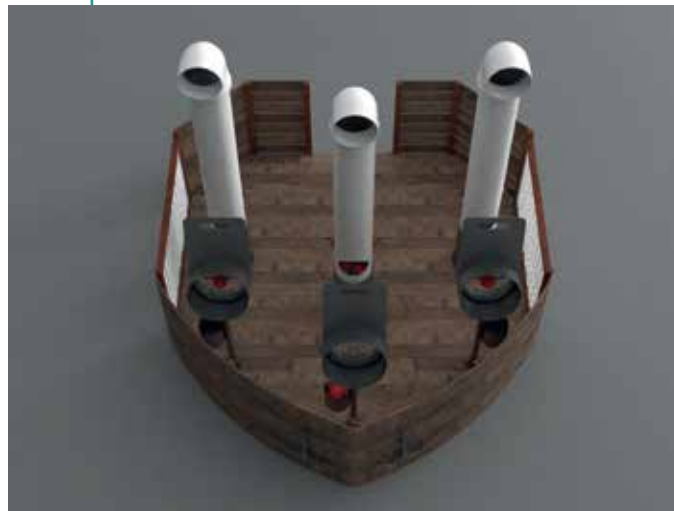
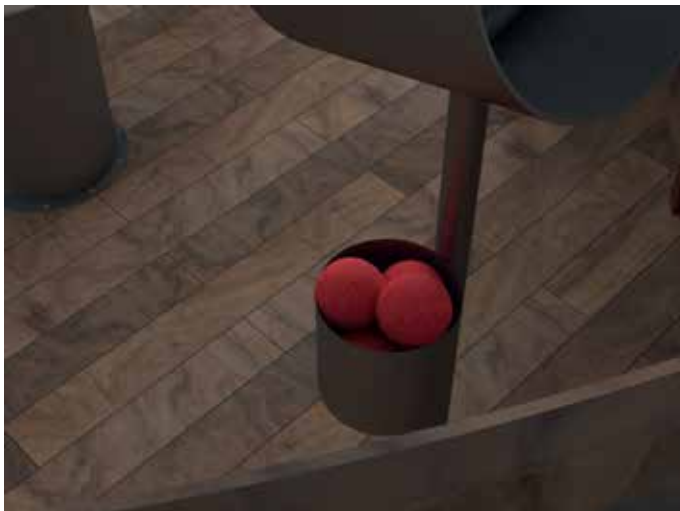



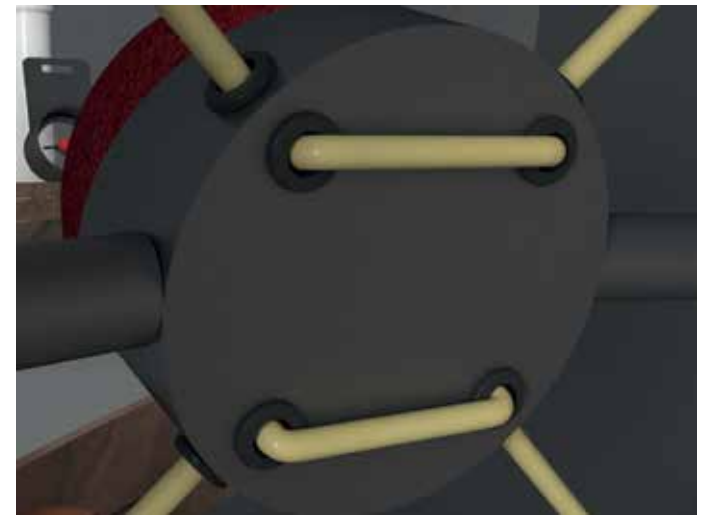
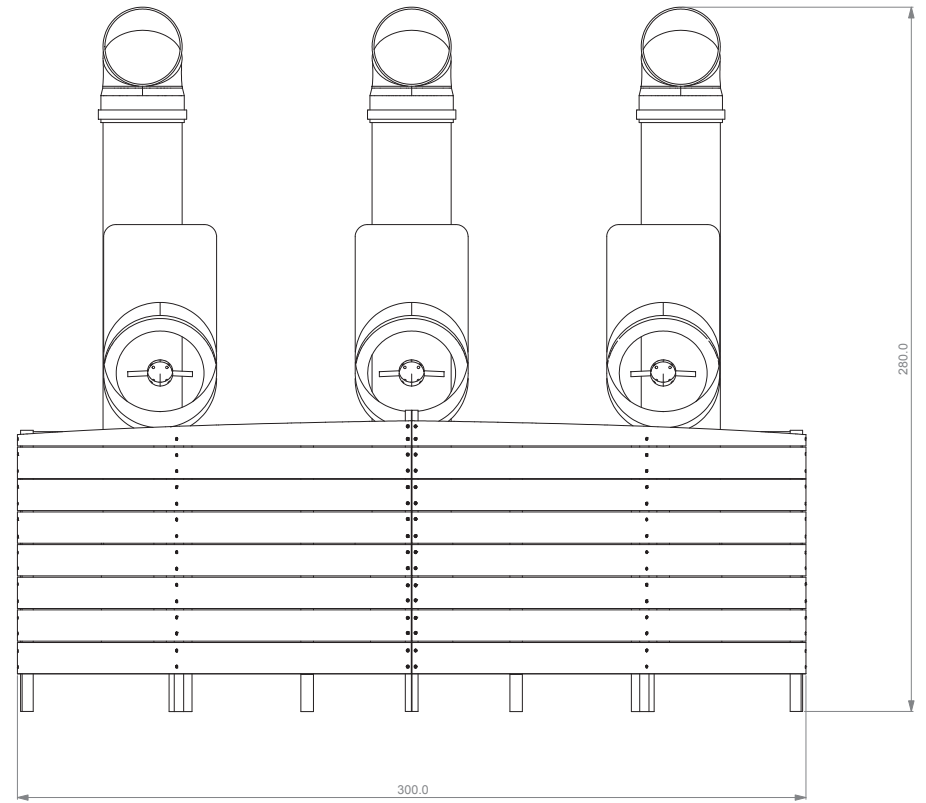
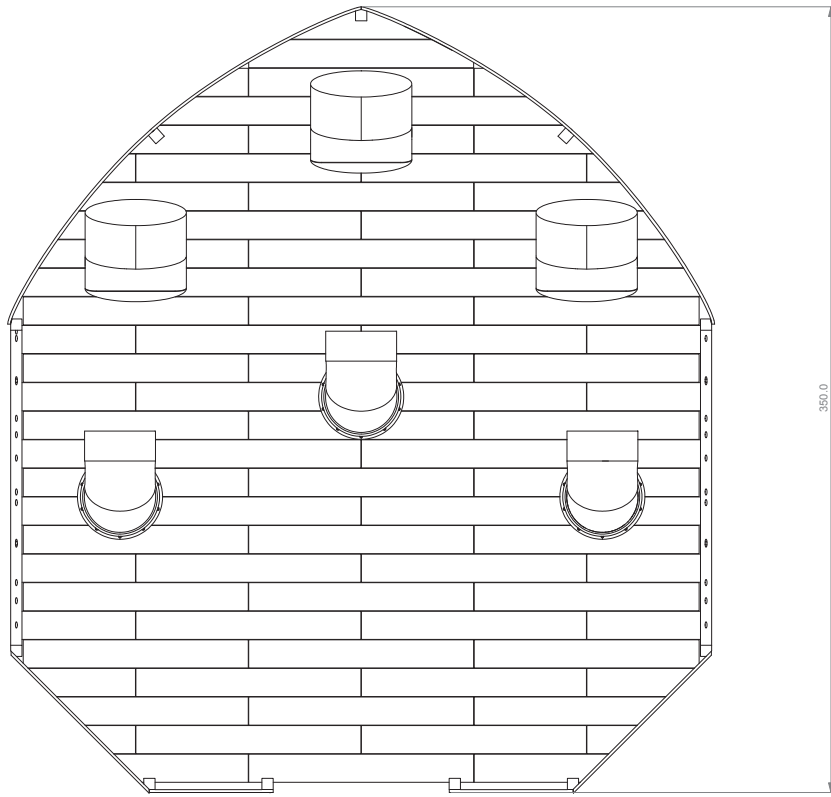



Martín Pérez Leiza
tincho1810@gmail.com
099 27 26 98

 18designuy

