

Universidad ORT Uruguay  
Facultad de Comunicación y Diseño

Carpeta anual 4

Entregado como requisito para la obtención del título de  
Licenciada en Diseño Industrial

Lucie Beare

172220

2015

Lb

LucieBeare

---

DISEÑO INDUSTRIAL

Buen diseño es crear algo comprensible y memorable...

# CONTENIDO

FOODJOY

---

TREKANT

---

LINEA CUBE

---

AURICULARES

---

PACMAN

---

TROMPI

---

# FOODJOY

---

Foodjoy es un kit de accesorios diseñado para mujeres, que permite cocinar una variedad de alimentos en la parrilla. Es un producto estético, fácil de limpiar, apilable, ergonómico y transportable.

*Foodjoy, an accessory kit designed for women who can cook a variety of food on the grill. It is esthetic, easy clean, stackable, ergonomic and transportable.*

---



BANDEJAS | TRAYS

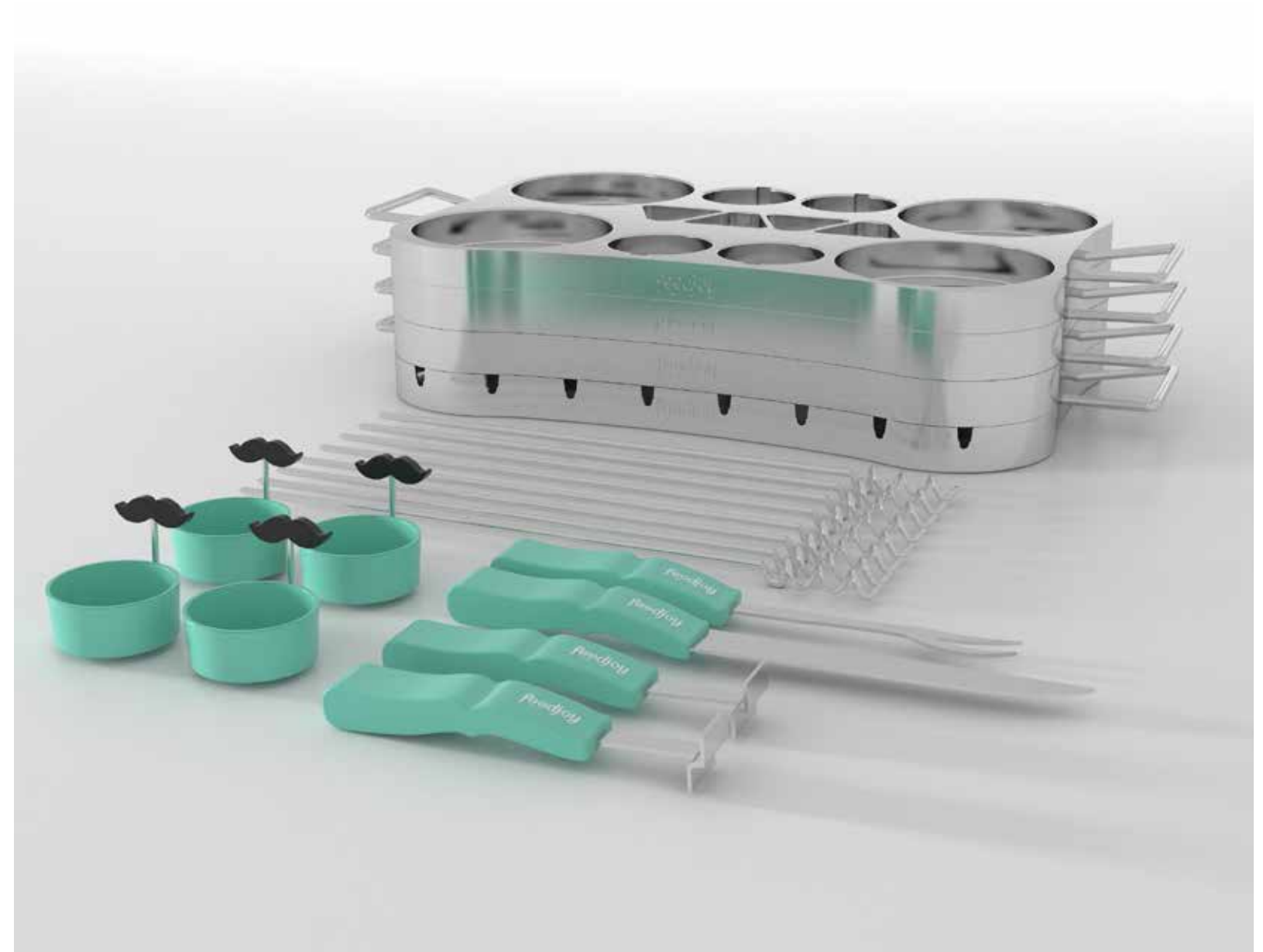
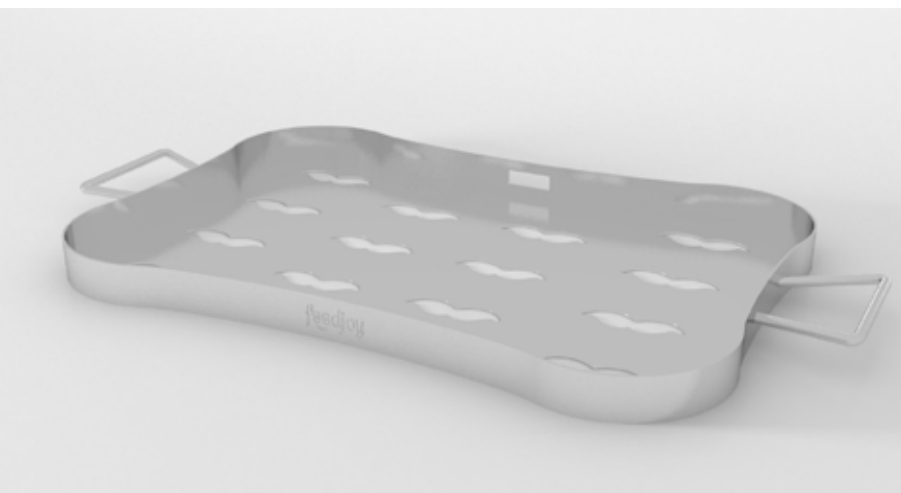
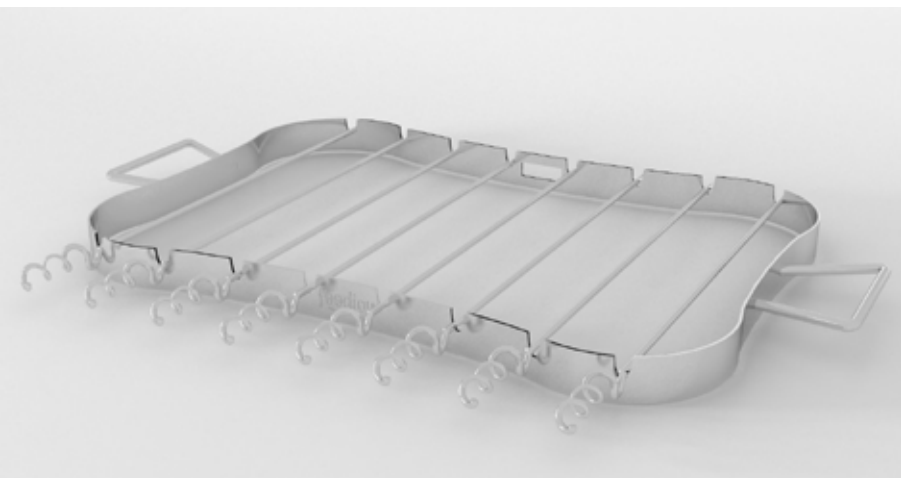

KIT DE ACCESORIOS | SET OF ACCESSORIES



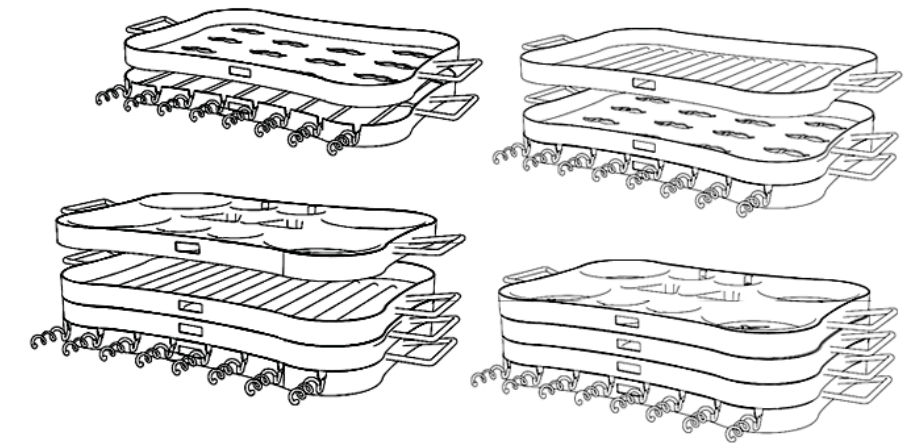



# TREKANT

Trekant es un exhibidor de joyas y objetos pequeños diseñado para el museo MAPI. Se basa en un panel fijo a la pared junto con sus seis módulos que permiten hacer diferentes combinaciones. Se define como un producto versátil, fácil de utilizar, y ergonómico, ya que puede ser manipulado por una sola persona.

*Trekant is a display of jewelry and small objects designed for MAPI museum. It is based on a fixed panel on the wall along with its six modules that allow different combinations. It is defined as a versatile, easy to use and ergonomic product as it can be handled by one person.*

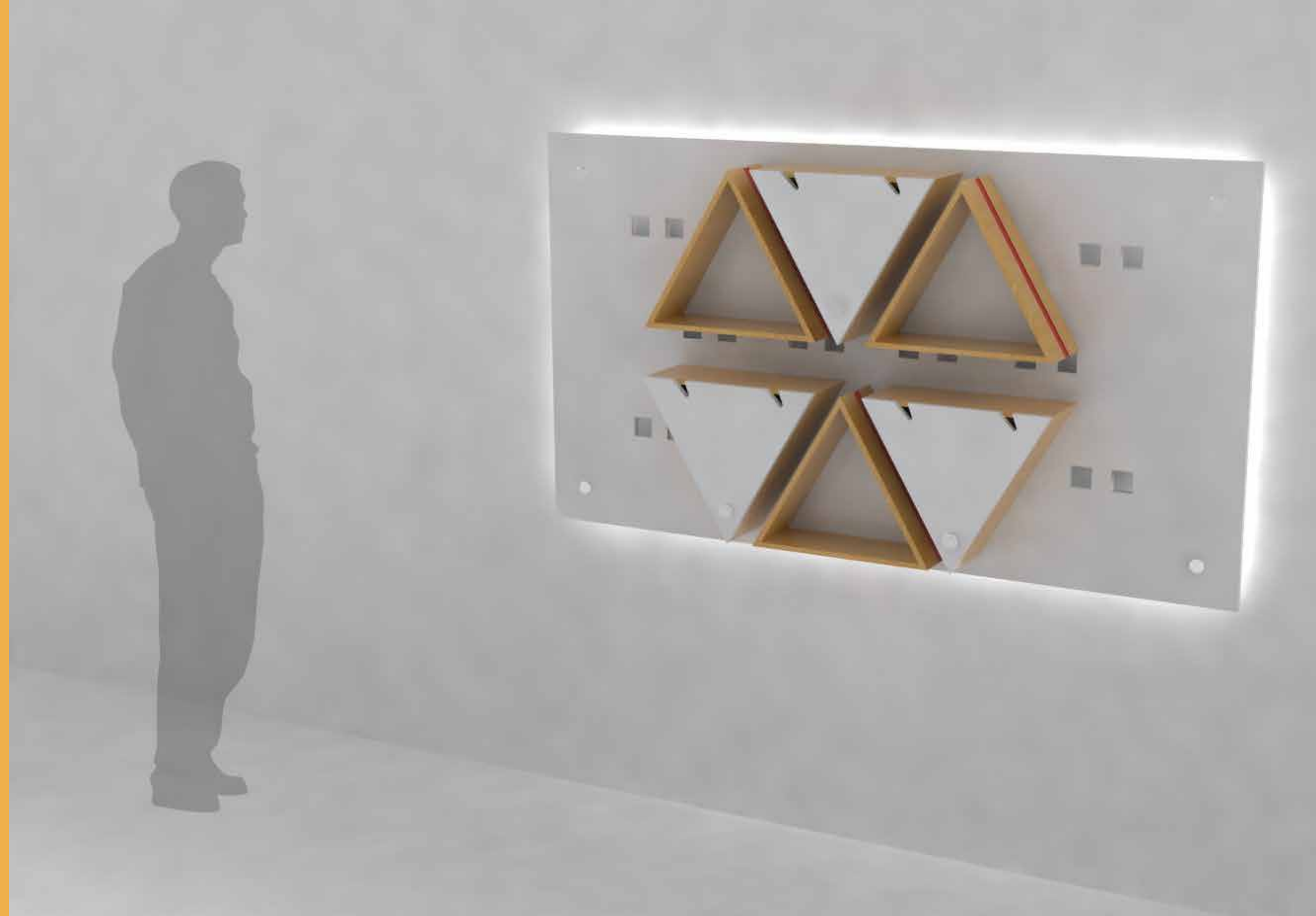



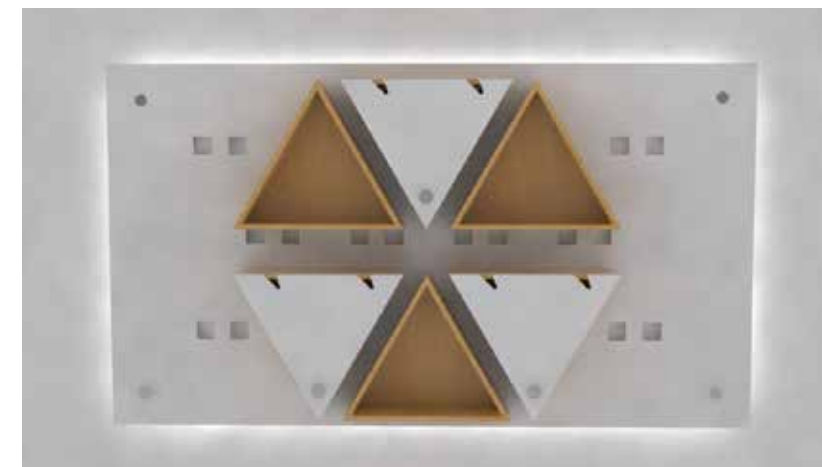
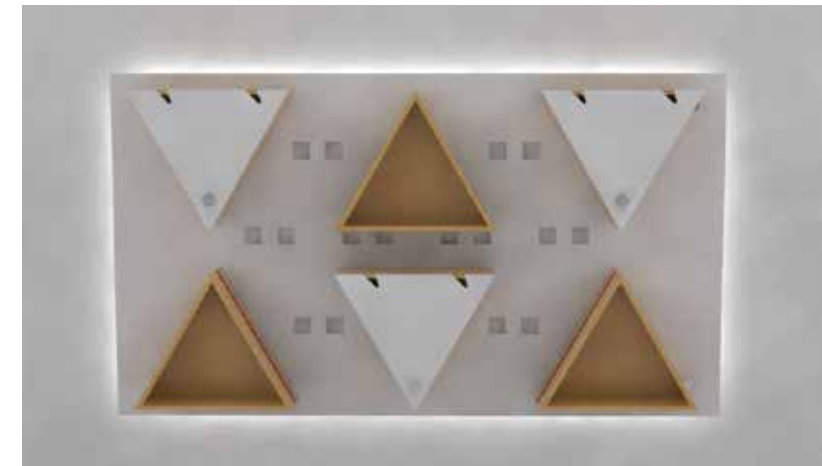

MODO DE USO | HOW TO USE

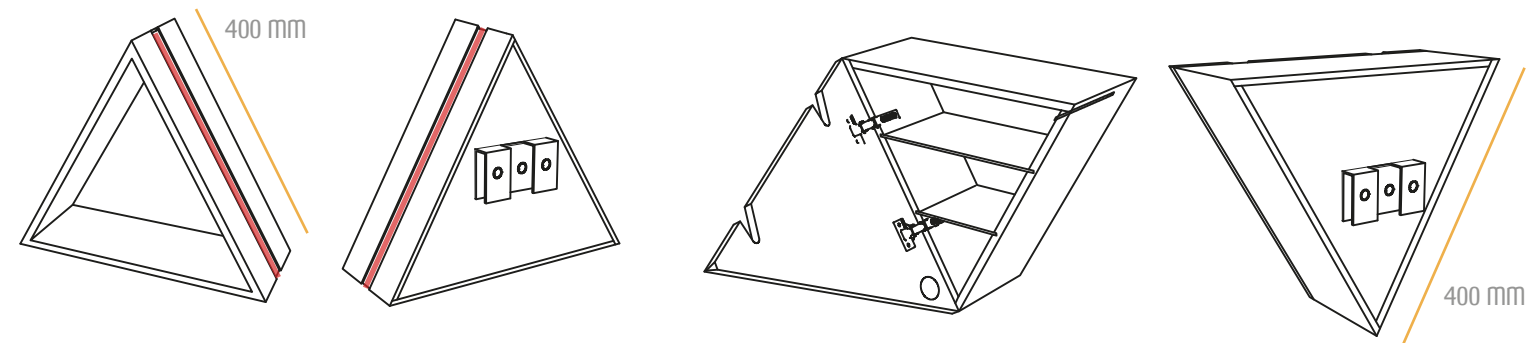

## LINEA CUBE

---

Cube consiste en una línea de productos para el entorno living diseñado para la empresa Lisää. Incluye un set de cuatro módulos diferentes permitiendo múltiples combinaciones según las necesidades del usuario, y además una luminaria de pie. La línea es de estilo nórdico, simple y cuenta con la multifuncionalidad.

*Cube is a line of products for the living-room designed for Lisää company. It includes a set of four different modules allowing multiple combinations according to user needs, and a floor lamp. It is Nordic, simple style and has multifunctionality.*

---





MÓDULOS | MODULES

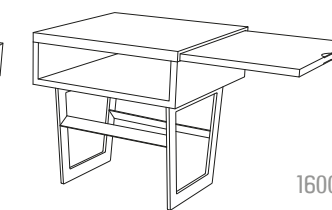
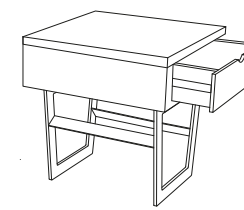
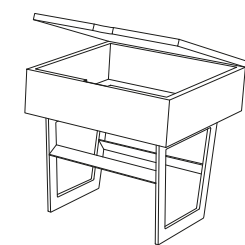
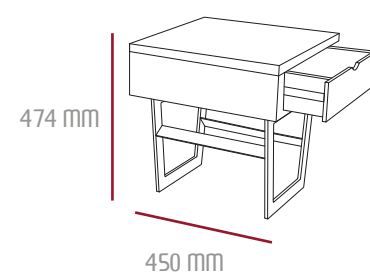

1600 mm

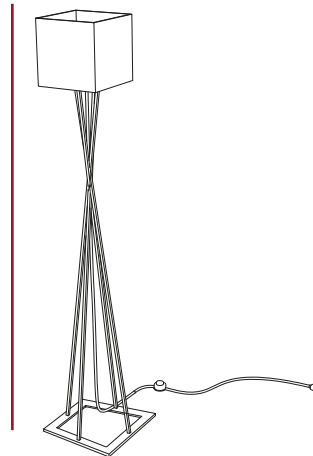

DIMENSIONES | DIMENSIONS





**Lisää**  
ALMACEN DE OBJETOS  
LINEA CUBE

MOBILIARIO MULTIFUNCIONAL  
LINEAS RECTAS ESTILO  
FINGER JOINT NÓRDICO  
FORMAS SIMPLES ACERO  
MODULAR COMBINAR  
MESA RATONA | LUMINARIA



# AURICULARES

---

Inspirados en las características de las motos BMW. El diseño simple de formas robustas, facetados, relieves, moderno y sofisticado. Se controlan a través de tecnología Bluetooth, y se pliegan para un mejor almacenamiento. A su vez tienen la posibilidad de personalización con variantes de colores que da al usuario sentido de pertenencia.

*Inspired by the features of BMW motorcycles. A simple design, facets, reliefs, modern and sophisticated design. They are controlled via Bluetooth technology, and fold for better storage. At the same time they have the possibility of customization with color variants that gives the user a sense of belonging.*

---



## MESA PACMAN

---

Mesa de luz o mesa auxiliar de estilo nórdico RTA. Su nombre se relaciona con el modo de almacenamiento, ya que su forma y estilo de almacenamiento simulan al "pacman".

*Side table RTA nordic style . Its name is related to the storage mode, as its shape and style of storage simulate the " Pacman " .*

---





VARIANTES | VARIETY

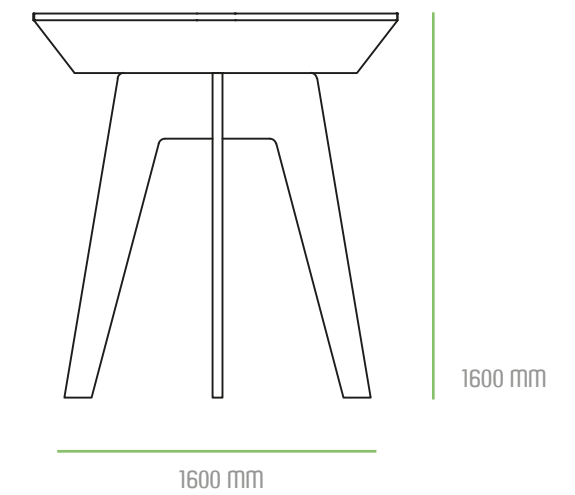
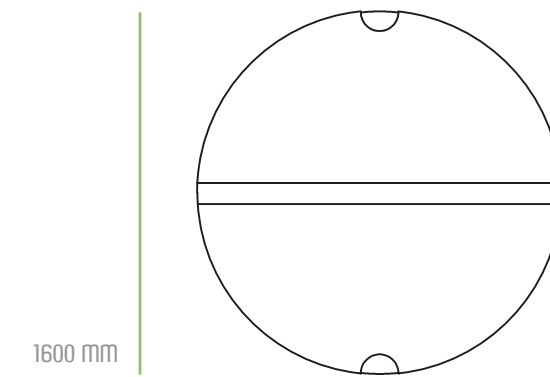

DIMENSIONES | DIMENSIONS



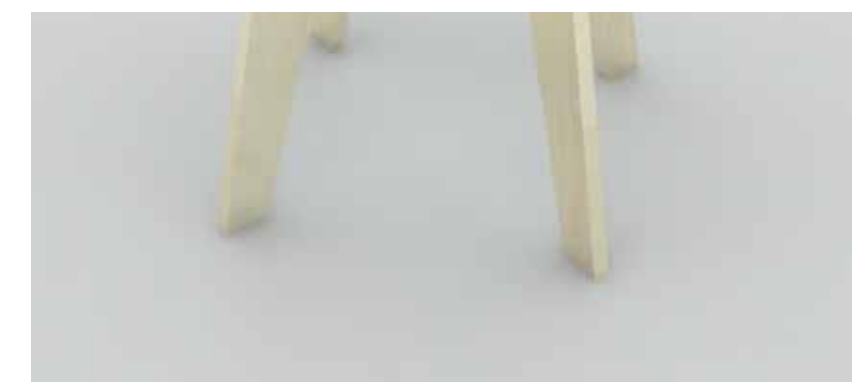
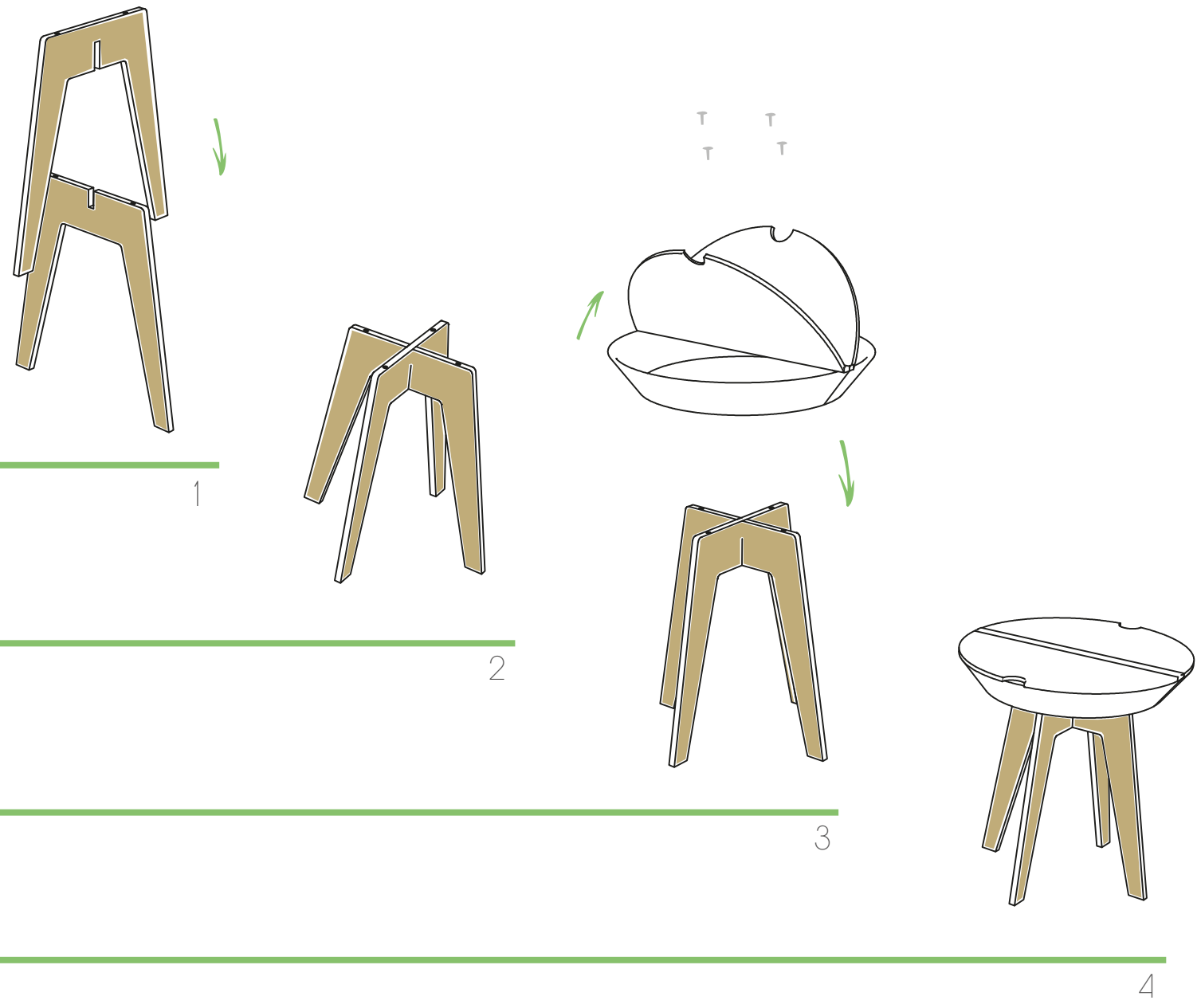

# TROMPI

---

Mobiliario infantil diseñado especialmente para niños entre dos y seis años. Trompi fue inspirado en imágenes de elefantes, combinando líneas curvas y rectas formando planos y apoyos para realizar actividades como dibujar, jugar o leer. Su forma ergonómica y confortable brinda seguridad y comodidad para el usuario.

*Children's furniture designed especially for children between two and six years. Trompi was inspired by images of elephants, combining straight and curved lines forming planes and support for activities such as drawing, playing or reading. Its comfortable and ergonomic shape, provides security and*



MATERIALES | MATERIALS

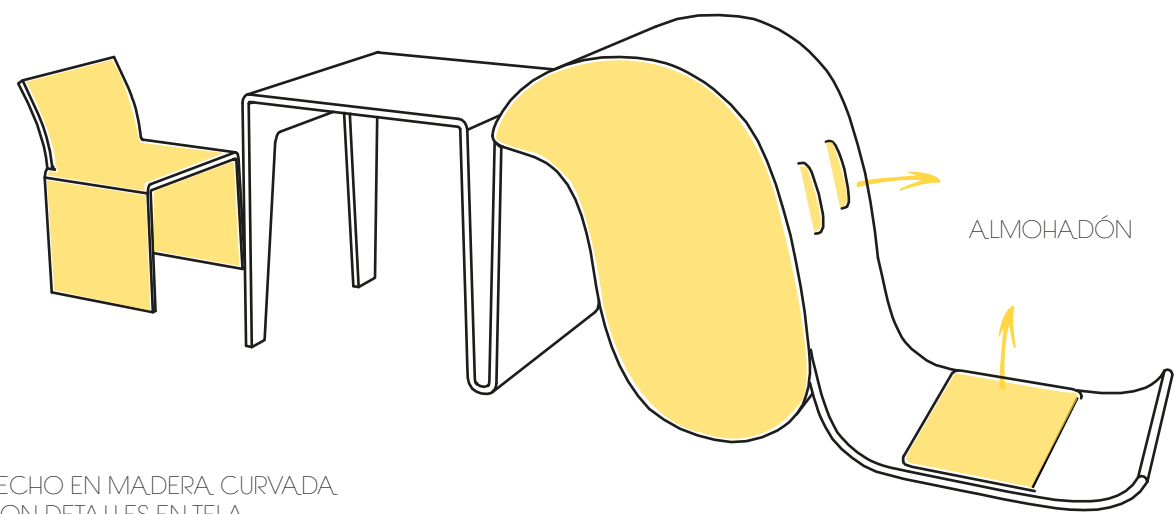

HECHO EN MADERA, CURVADA,  
CON DETALLES EN TELA.

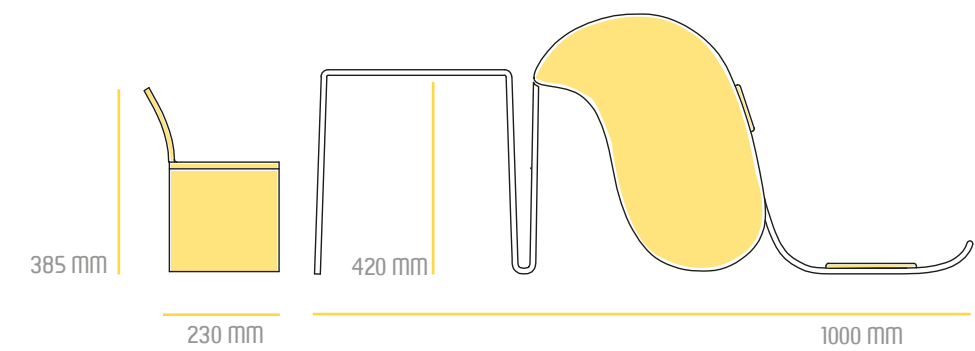

DIMENSIONES | DIMENSIONS

VARIANTES | VARIETY

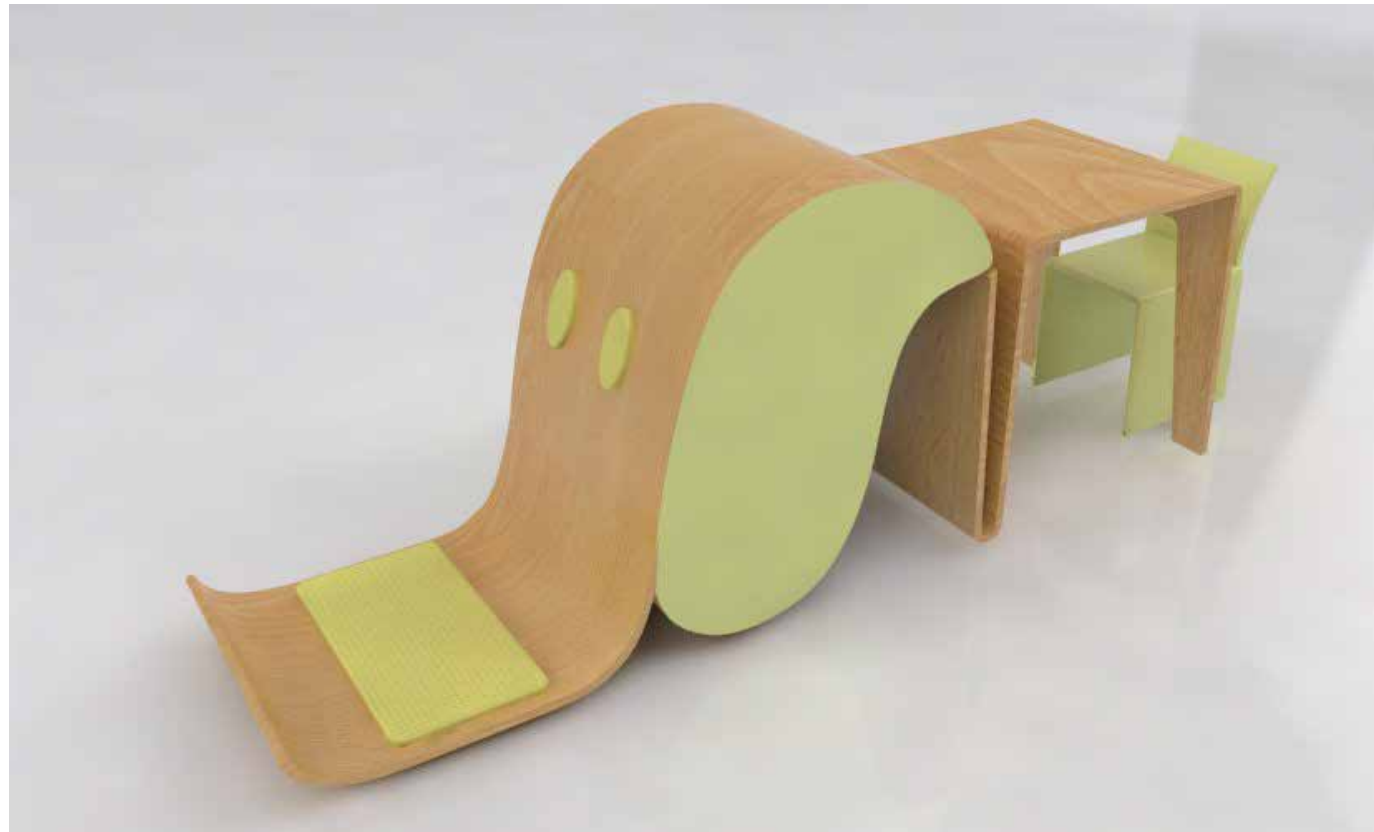

DETALLES | DETAILS



GRACIAS! • THANKS!

---

· Lucie Beare ·  
luciebeare@gmail.com

Gran diseño es crear algo memorable y que tenga sentido.

·Dieter Rams·

